

## Digitally Controlled Potentiometer (XDCP™)

The X9C102, X9C103, X9C104, X9C503 are Intersil's digitally controlled (XDCP) potentiometers. The device consists of a resistor array, wiper switches, a control section, and non-volatile memory. The wiper position is controlled by a three-wire interface.

The potentiometer is implemented by a resistor array composed of 99 resistive elements and a wiper switching network. Between each element and at either end are tap points accessible to the wiper terminal. The position of the wiper element is controlled by the CS, U/D, and INC inputs. The position of the wiper can be stored in non-volatile memory and then be recalled upon a subsequent power-up operation.

The device can be used as a three-terminal potentiometer or as a two-terminal variable resistor in a wide variety of applications ranging from control to signal processing to parameter adjustment.

### Pinout

**X9C102, X9C103, X9C104, X9C503**  
(8 LD SOIC, 8 LD PDIP)  
TOP VIEW

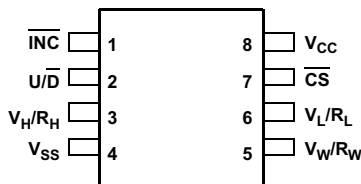

### Features

- Solid-State Potentiometer
- Three-Wire Serial Interface
- 100 Wiper Tap Points
  - Wiper Position Stored in Non-volatile Memory and Recalled on Power-up
- 99 Resistive Elements
  - Temperature Compensated
  - End-to-End Resistance,  $\pm 20\%$
  - Terminal Voltages,  $\pm 5V$
- Low Power CMOS
  - $V_{CC} = 5V$
  - Active Current, 3mA max.
  - Standby Current, 750 $\mu$ A max.
- High Reliability
  - Endurance, 100,000 Data Changes per Bit
  - Register Data Retention, 100 years
- X9C102 = 1k $\Omega$
- X9C103 = 10k $\Omega$
- X9C503 = 50k $\Omega$
- X9C104 = 100k $\Omega$
- Packages
  - 8 Ld SOIC
  - 8 Ld PDIP
- Pb-Free Available (RoHS Compliant)

### Block Diagram

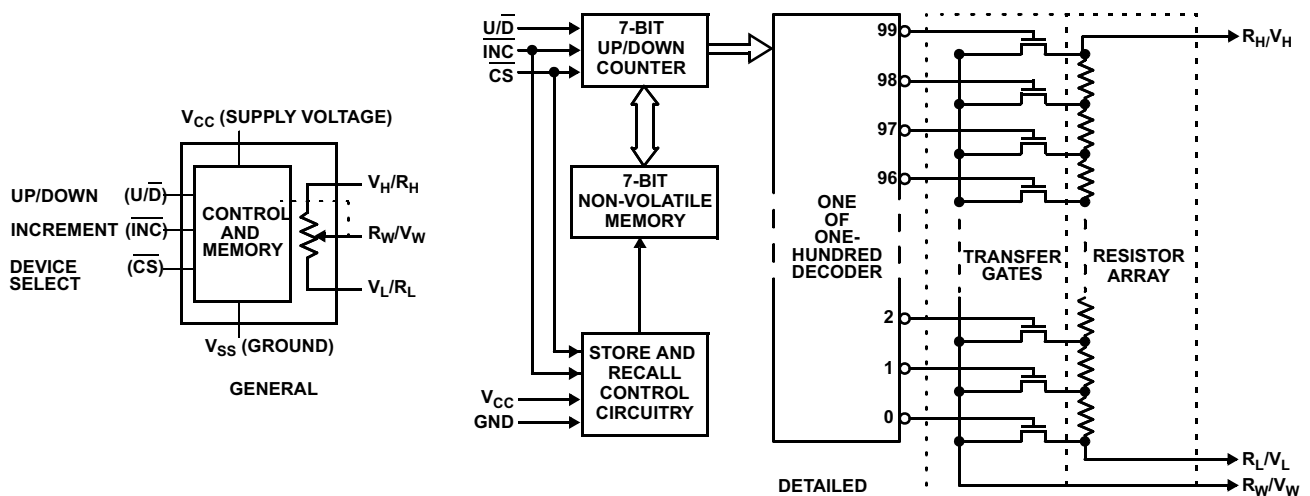

## X9C102, X9C103, X9C104, X9C503

### Ordering Information

PART NUMBER	PART MARKING	R <sub>TOTAL</sub> (kΩ)	TEMP RANGE (°C)	PACKAGE	PACKAGE DWG. #
X9C102P	X9C102P	1	0 to +70	8 Ld PDIP	MDP0031
X9C102PZ (Notes 1, 2)	X9C102P Z		0 to +70	8 Ld PDIP (Pb-free)	MDP0031
X9C102PI	X9C102P I		-40 to +85	8 Ld PDIP	MDP0031
X9C102PIZ (Notes 1, 2)	X9C102P ZI		-40 to +85	8 Ld PDIP (Pb-free)	MDP0031
X9C102S*, **	X9C102S		0 to +70	8 Ld SOIC	MDP0027
X9C102SZ* (Note 1)	X9C102S Z		0 to +70	8 Ld SOIC (Pb-free)	MDP0027
X9C102SI*, **	X9C102S I		-40 to +85	8 Ld SOIC	MDP0027
X9C102SIZ*, ** (Note 1)	X9C102S ZI		-40 to +85	8 Ld SOIC (Pb-free)	MDP0027
X9C103P	X9C103P	10	0 to +70	8 Ld PDIP	MDP0031
X9C103PZ (Notes 1, 2)	X9C103P Z		0 to +70	8 Ld PDIP (Pb-free)	MDP0031
X9C103PI	X9C103P I		-40 to +85	8 Ld PDIP	MDP0031
X9C103PIZ (Note 1)	X9C103P ZI		-40 to +85	8 Ld PDIP (Pb-free)	MDP0031
X9C103S*, **	X9C103S		0 to +70	8 Ld SOIC	MDP0027
X9C103SZ*, ** (Note 1)	X9C103S Z		0 to +70	8 Ld SOIC (Pb-free)	MDP0027
X9C103SI*, **	X9C103S I		-40 to +85	8 Ld SOIC	MDP0027
X9C103SIZ*, ** (Note 1)	X9C103S ZI		-40 to +85	8 Ld SOIC (Pb-free)	MDP0027
X9C503P	X9C503P	50	0 to +70	8 Ld PDIP	MDP0031
X9C503PZ (Notes 1, 2)	X9C503P Z		0 to +70	8 Ld PDIP (Pb-free)	MDP0031
X9C503PI	X9C503P I		-40 to +85	8 Ld PDIP	MDP0031
X9C503PIZ (Notes 1, 2)	X9C503P ZI		-40 to +85	8 Ld PDIP (Pb-free)	MDP0031
X9C503S*	X9C503S		0 to +70	8 Ld SOIC	MDP0027
X9C503SZ* (Note 1)	X9C503S Z		0 to +70	8 Ld SOIC (Pb-free)	MDP0027
X9C503SI*, **	X9C503S I		-40 to +85	8 Ld SOIC	MDP0027
X9C503SIZ*, ** (Note 1)	X9C503S ZI		-40 to +85	8 Ld SOIC (Pb-free)	MDP0027
X9C104P	X9C104P	100	0 to +70	8 Ld PDIP	MDP0031
X9C104PI	X9C104P I		-40 to +85	8 Ld PDIP	MDP0031
X9C104PIZ (Notes 1, 2)	X9C104P ZI		-40 to +85	8 Ld PDIP (Pb-free)	MDP0031
X9C104S*, **	X9C104S		0 to +70	8 Ld SOIC	MDP0027
X9C104SZ*, ** (Note 1)	X9C104S Z		0 to +70	8 Ld SOIC (Pb-free)	MDP0027
X9C104SI*, **	X9C104S I		-40 to +85	8 Ld SOIC	MDP0027
X9C104SIZ*, ** (Note 1)	X9C104S ZI		-40 to +85	8 Ld SOIC (Pb-free)	MDP0027

\*Add "T1" suffix for tape and reel. Please refer to TB347 for details on reel specifications.

\*\*Add "T2" suffix for tape and reel. Please refer to TB347 for details on reel specifications.

#### NOTES:

- These Intersil Pb-free plastic packaged products employ special Pb-free material sets, molding compounds/die attach materials, and 100% matte tin plate plus anneal (e3 termination finish, which is RoHS compliant and compatible with both SnPb and Pb-free soldering operations). Intersil Pb-free products are MSL classified at Pb-free peak reflow temperatures that meet or exceed the Pb-free requirements of IPC/JEDEC J STD-020.
- Pb-free PDIPs can be used for through-hole wave solder processing only. They are not intended for use in Reflow solder processing applications.

## X9C102, X9C103, X9C104, X9C503

### Pin Descriptions

PIN NUMBER	PIN NAME	DESCRIPTION
1	$\overline{\text{INC}}$	<b>INCREMENT</b> The $\overline{\text{INC}}$ input is negative-edge triggered. Toggling $\overline{\text{INC}}$ will move the wiper and either increment or decrement the counter in the direction indicated by the logic level on the U/D input.
2	U/D	<b>UP/DOWN</b> The U/D input controls the direction of the wiper movement and whether the counter is incremented or decremented.
3	$V_H/R_H$	<b><math>V_H/R_H</math></b> The high ( $V_H/R_H$ ) terminals of the X9C102, X9C103, X9C104, X9C503 are equivalent to the fixed terminals of a mechanical potentiometer. The minimum voltage is -5V and the maximum is +5V. The terminology of $V_H/R_H$ and $V_L/R_L$ references the relative position of the terminal in relation to wiper movement direction selected by the U/D input and not the voltage potential on the terminal.
4	$V_{SS}$	<b><math>V_{SS}</math></b>
5	$V_W/R_W$	<b><math>V_W/R_W</math></b> $V_W/R_W$ is the wiper terminal and is equivalent to the movable terminal of a mechanical potentiometer. The position of the wiper within the array is determined by the control inputs. The wiper terminal series resistance is typically 40 $\Omega$ .
6	$R_L/V_L$	<b><math>R_L/V_L</math></b> The low ( $V_L/R_L$ ) terminals of the X9C102, X9C103, X9C104, X9C503 are equivalent to the fixed terminals of a mechanical potentiometer. The minimum voltage is -5V and the maximum is +5V. The terminology of $V_H/R_H$ and $V_L/R_L$ references the relative position of the terminal in relation to wiper movement direction selected by the U/D input and not the voltage potential on the terminal.
7	$\overline{\text{CS}}$	<b><math>\overline{\text{CS}}</math></b> The device is selected when the $\overline{\text{CS}}$ input is LOW. The current counter value is stored in non-volatile memory when $\overline{\text{CS}}$ is returned HIGH while the $\overline{\text{INC}}$ input is also HIGH. After the store operation is complete the X9C102, X9C103, X9C104, X9C503 device will be placed in the low power standby mode until the device is selected once again.
8	$V_{CC}$	<b><math>V_{CC}</math></b>



## X9C102, X9C103, X9C104, X9C503

### Electrical Specifications Over recommended operating conditions unless otherwise stated. (Continued)

SYMBOL	PARAMETER	TEST CONDITIONS	LIMITS			UNIT
			MIN	TYP (Note 6)	MAX	
<b>AC OPERATION CHARACTERISTICS</b>						
$t_{CI}$	$\overline{CS}$ to $\overline{INC}$ Setup		100			ns
$t_{ID}$	$\overline{INC}$ HIGH to $U/\overline{D}$ Change		100			ns
$t_{DI}$	$U/\overline{D}$ to $\overline{INC}$ Setup		2.9			$\mu$ s
$t_{iL}$	$\overline{INC}$ LOW Period		1			$\mu$ s
$t_{iH}$	$\overline{INC}$ HIGH Period		1			$\mu$ s
$t_{iC}$	$\overline{INC}$ Inactive to $\overline{CS}$ Inactive		1			$\mu$ s
$t_{CPH}$	$\overline{CS}$ Deselect Time (STORE)		20			ms
$t_{CPH}$	$\overline{CS}$ Deselect Time (NO STORE)		100			ns
$t_{iW}^{(5)}$	$\overline{INC}$ to $V_{W/RW}$ Change			100		$\mu$ s
$t_{CYC}$	$\overline{INC}$ Cycle Time		2			$\mu$ s
$t_{CYC}$	$\overline{INC}$ Input Rise and Fall Time				500	$\mu$ s
$t_R, t_F$	Power-up to Wiper Stable (Note 7)			500		$\mu$ s
$t_{PU}$	$V_{CC}$ Power-up Rate (Note 7)		0.2		50	V/ms

**NOTES:**

3. Absolute linearity is utilized to determine actual wiper voltage vs expected voltage =  $[V_{W(n)(actual)} - V_{W(n)(expected)}] = \pm 1$  MI Maximum.
4. Relative linearity is a measure of the error in step size between taps =  $V_{W(n+1)} - [V_{W(n)} + MI] = +0.2$  MI.
5. 1 MI = Minimum Increment =  $R_{TOT}/99$ .
6. Typical values are for  $T_A = +25^\circ\text{C}$  and nominal supply voltage.
7. This parameter is not 100% tested.

**Test Circuit #1**

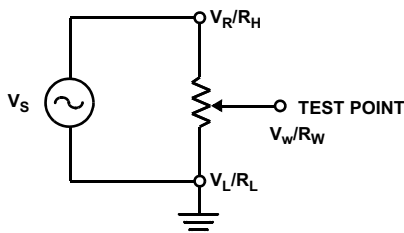

**Test Circuit #2**

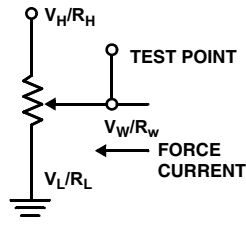

**Circuit #3 SPICE Macro Model**

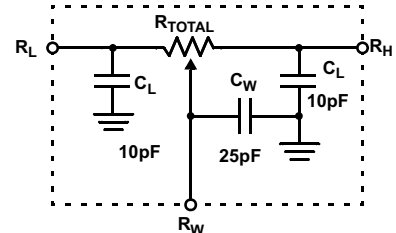

**Endurance and Data Retention**

PARAMETER	MIN	UNIT
Medium Endurance	100,000	Data changes per bit per register
Data Retention	100	years

**Power-up and Down Requirements**

At all times, voltages on the potentiometer pins must be less than  $\pm V_{CC}$ . The recall of the wiper position from non-volatile memory is not in effect until the  $V_{CC}$  supply reaches its final value. The  $V_{CC}$  ramp rate specification is always in effect.

**AC Conditions of Test**

Input Pulse Levels	0V to 3V
Input Rise and Fall Times	10ns
Input Reference Levels	1.5V

**AC Timing Diagram**

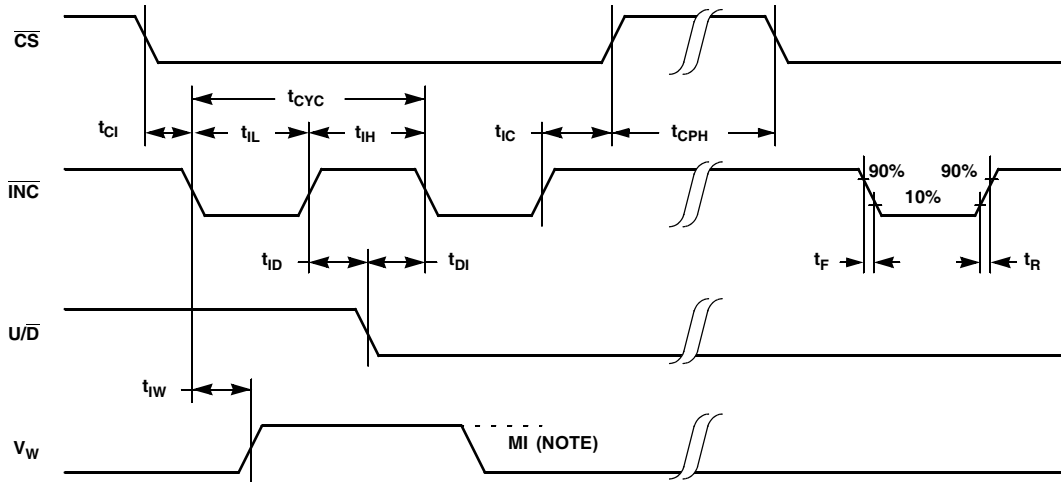

NOTE: MI REFERS TO THE MINIMUM INCREMENTAL CHANGE IN THE  $V_w$  OUTPUT DUE TO A CHANGE IN THE WIPER POSITION.

**Pin Descriptions**

**$R_H/V_H$  and  $R_L/V_L$**

The high ( $V_H/R_H$ ) and low ( $V_L/R_L$ ) terminals of the ISLX9C102, X9C103, X9C104, X9C503 are equivalent to the fixed terminals of a mechanical potentiometer. The minimum voltage is -5V and the maximum is +5V. The terminology of  $V_H/R_H$  and  $V_L/R_L$  references the relative position of the terminal in relation to wiper movement direction selected by the  $\overline{U/D}$  input and not the voltage potential on the terminal.

**$R_W/V_W$**

$V_W/R_W$  is the wiper terminal, and is equivalent to the movable terminal of a mechanical potentiometer. The position of the wiper within the array is determined by the control inputs. The wiper terminal series resistance is typically 40Ω.

**Up/Down ( $\overline{U/D}$ )**

The  $\overline{U/D}$  input controls the direction of the wiper movement and whether the counter is incremented or decremented.

**Increment ( $\overline{INC}$ )**

The  $\overline{INC}$  input is negative-edge triggered. Toggling  $\overline{INC}$  will move the wiper and either increment or decrement the counter in the direction indicated by the logic level on the  $\overline{U/D}$  input.

**Chip Select ( $\overline{CS}$ )**

The device is selected when the  $\overline{CS}$  input is LOW. The current counter value is stored in non-volatile memory when  $\overline{CS}$  is returned HIGH while the  $\overline{INC}$  input is also HIGH. After the store operation is complete the ISLX9C102, X9C103, X9C104, X9C503 device will be placed in the low power standby mode until the device is selected once again.

**Principles of Operation**

There are three sections of the X9C102, X9C103, ISL9C104 and ISL9C503: the input control, counter and decode section; the non-volatile memory; and the resistor array. The input control section operates just like an up/down counter. The output of this counter is decoded to turn on a single electronic switch connecting a point on the resistor array to the wiper output. Under the proper conditions, the contents of the counter can be stored in non-volatile memory and retained for future use. The resistor array is comprised of 99 individual resistors connected in series. At either end of the array and between each resistor is an electronic switch that transfers the potential at that point to the wiper.

The wiper, when at either fixed terminal, acts like its mechanical equivalent and does not move beyond the last position. That is, the counter does not wrap around when clocked to either extreme.

The electronic switches on the device operate in a "make-before-break" mode when the wiper changes tap positions. If the wiper is moved several positions, multiple taps are connected to the wiper for  $t_{IW}$  ( $\overline{INC}$  to  $V_W/R_W$  change). The  $R_{TOTAL}$  value for the device can temporarily be reduced by a significant amount if the wiper is moved several positions.

When the device is powered-down, the last wiper position stored will be maintained in the non-volatile memory. When power is restored, the contents of the memory are recalled and the wiper is reset to the value last stored.

The internal charge pump allows a wide range of voltages (from -5V to 5V) applied to XDCP terminals yet given a convenience of single power supply. The typical charge pump noise of 20mV at 850kHz should be taken in consideration when designing an application circuit.

**Instructions and Programming**

The  $\overline{INC}$ ,  $U/\overline{D}$  and  $\overline{CS}$  inputs control the movement of the wiper along the resistor array. With  $\overline{CS}$  set LOW, the device is selected and enabled to respond to the  $U/\overline{D}$  and  $\overline{INC}$  inputs. HIGH to LOW transitions on  $\overline{INC}$  will increment or decrement (depending on the state of the  $U/\overline{D}$  input) a 7-bit counter. The output of this counter is decoded to select one of one-hundred wiper positions along the resistive array.

The value of the counter is stored in non-volatile memory whenever  $\overline{CS}$  transitions HIGH while the  $\overline{INC}$  input is also HIGH.

The system may select the X9Cxxx, move the wiper and deselect the device without having to store the latest wiper position in non-volatile memory. After the wiper movement is performed as previously described and once the new position is reached, the system must keep  $\overline{INC}$  LOW while taking  $\overline{CS}$  HIGH. The new wiper position will be maintained until changed by the system or until a power-down/up cycle recalled the previously stored data.

This procedure allows the system to always power-up to a pre-set value stored in non-volatile memory; then during system operation, minor adjustments could be made. The adjustments might be based on user preference, i.e.: system parameter changes due to temperature drift, etc.

The state of  $U/\overline{D}$  may be changed while  $\overline{CS}$  remains LOW. This allows the host system to enable the device and then move the wiper up and down until the proper trim is attained.

**Mode Selection**

$\overline{CS}$	$\overline{INC}$	$U/\overline{D}$	MODE
L		H	Wiper Up
L		L	Wiper Down
	H	X	Store Wiper Position
H	X	X	Standby Current
	L	X	No Store, Return to Standby
	L	H	Wiper Up (not recommended)
	L	L	Wiper Down (not recommended)

**Symbol Table**

WAVEFORM	INPUTS	OUTPUTS
	Must be steady	Will be steady
	May change from Low to High	Will change from Low to High
	May change from High to Low	Will change from High to Low
	Don't Care: Changes Allowed	Changing: State Not Known
	N/A	Center Line is High Impedance

**Performance Characteristics**

Contact the factory for more information.

**Applications Information**

Electronic digitally controlled (XCDP) potentiometers provide three powerful application advantages:

1. The variability and reliability of a solid-state potentiometer.
2. The flexibility of computer-based digital controls.
3. The retentivity of non-volatile memory used for the storage of multiple potentiometer settings or data.

Basic Configurations of Electronic Potentiometers

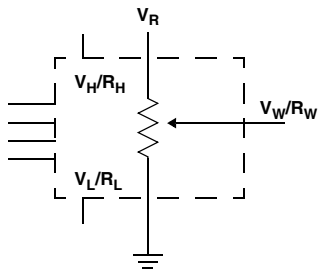

THREE TERMINAL POTENTIOMETER;  
VARIABLE VOLTAGE DIVIDER

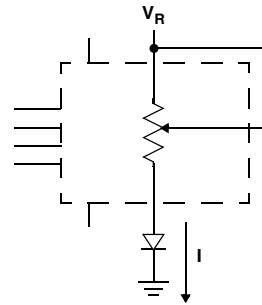

TWO TERMINAL VARIABLE RESISTOR;  
VARIABLE CURRENT

Basic Circuits

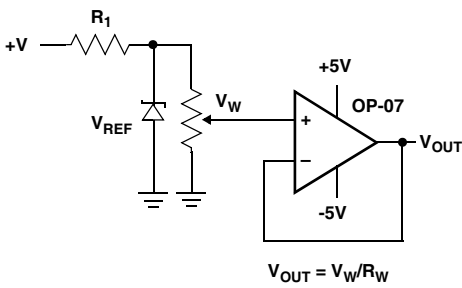

BUFFERED REFERENCE VOLTAGE

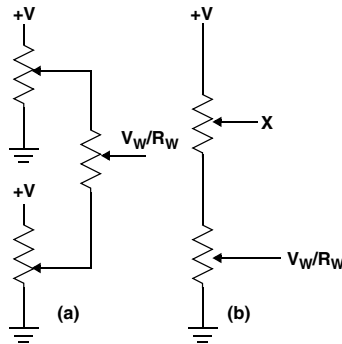

CASCADING TECHNIQUES

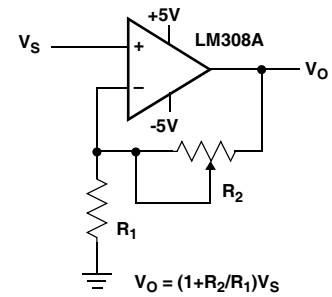

NONINVERTING AMPLIFIER

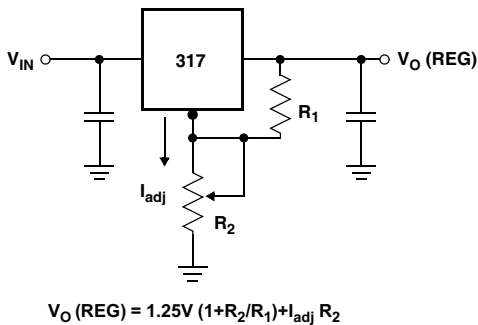

VOLTAGE REGULATOR

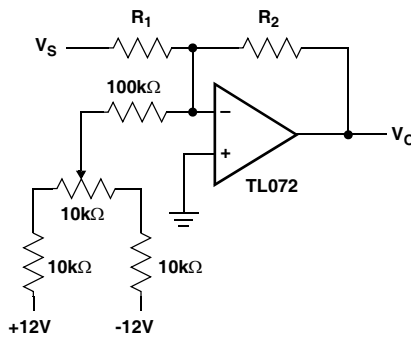

OFFSET VOLTAGE ADJUSTMENT

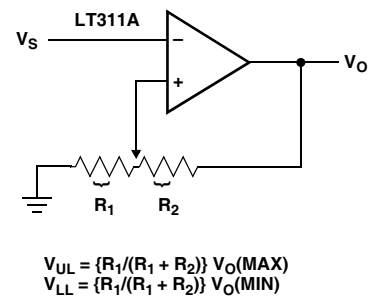

(FOR ADDITIONAL CIRCUITS SEE AN1145)

COMPARATOR WITH HYSTERESIS



## X9C102, X9C103, X9C104, X9C503

### Small Outline Package Family (SO)

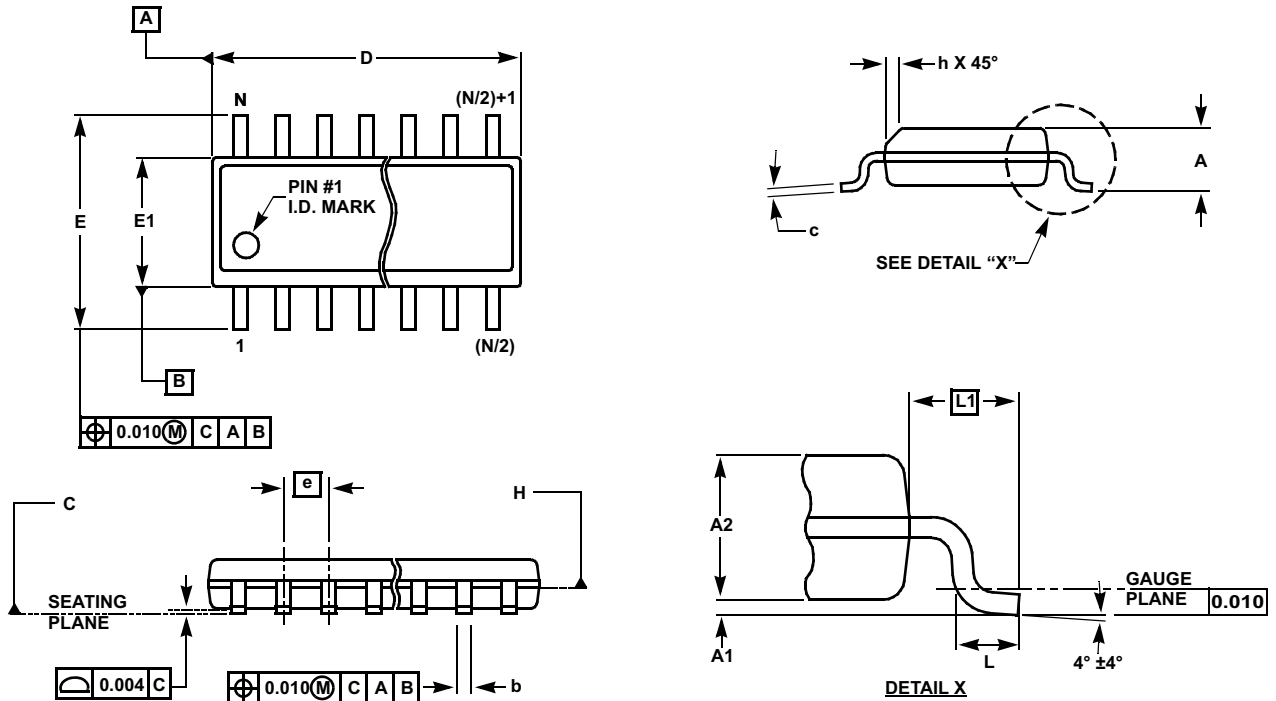

### MDP0027

#### SMALL OUTLINE PACKAGE FAMILY (SO)

SYMBOL	INCHES							TOLERANCE	NOTES
	SO-8	SO-14	SO16 (0.150")	SO16 (0.300") (SOL-16)	SO20 (SOL-20)	SO24 (SOL-24)	SO28 (SOL-28)		
A	0.068	0.068	0.068	0.104	0.104	0.104	0.104	MAX	-
A1	0.006	0.006	0.006	0.007	0.007	0.007	0.007	±0.003	-
A2	0.057	0.057	0.057	0.092	0.092	0.092	0.092	±0.002	-
b	0.017	0.017	0.017	0.017	0.017	0.017	0.017	±0.003	-
c	0.009	0.009	0.009	0.011	0.011	0.011	0.011	±0.001	-
D	0.193	0.341	0.390	0.406	0.504	0.606	0.704	±0.004	1, 3
E	0.236	0.236	0.236	0.406	0.406	0.406	0.406	±0.008	-
E1	0.154	0.154	0.154	0.295	0.295	0.295	0.295	±0.004	2, 3
e	0.050	0.050	0.050	0.050	0.050	0.050	0.050	Basic	-
L	0.025	0.025	0.025	0.030	0.030	0.030	0.030	±0.009	-
L1	0.041	0.041	0.041	0.056	0.056	0.056	0.056	Basic	-
h	0.013	0.013	0.013	0.020	0.020	0.020	0.020	Reference	-
N	8	14	16	16	20	24	28	Reference	-

Rev. M 2/07

#### NOTES:

1. Plastic or metal protrusions of 0.006" maximum per side are not included.
2. Plastic interlead protrusions of 0.010" maximum per side are not included.
3. Dimensions "D" and "E1" are measured at Datum Plane "H".
4. Dimensioning and tolerancing per ASME Y14.5M-1994

## X9C102, X9C103, X9C104, X9C503

### Plastic Dual-In-Line Packages (PDIP)

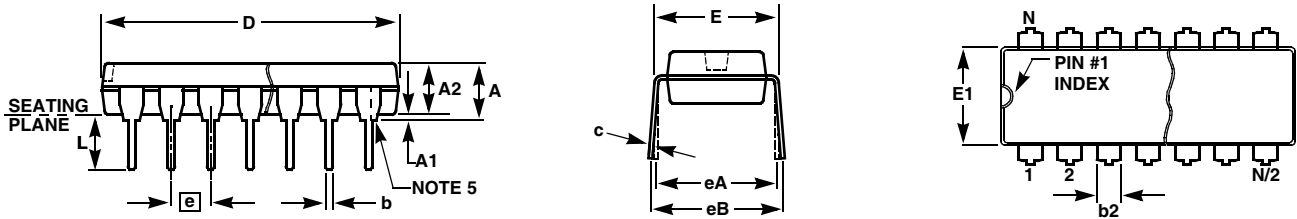

### MDP0031

#### PLASTIC DUAL-IN-LINE PACKAGE

SYMBOL	INCHES					TOLERANCE	NOTES
	PDIP8	PDIP14	PDIP16	PDIP18	PDIP20		
A	0.210	0.210	0.210	0.210	0.210	MAX	
A1	0.015	0.015	0.015	0.015	0.015	MIN	
A2	0.130	0.130	0.130	0.130	0.130	±0.005	
b	0.018	0.018	0.018	0.018	0.018	±0.002	
b2	0.060	0.060	0.060	0.060	0.060	+0.010/-0.015	
c	0.010	0.010	0.010	0.010	0.010	+0.004/-0.002	
D	0.375	0.750	0.750	0.890	1.020	±0.010	1
E	0.310	0.310	0.310	0.310	0.310	+0.015/-0.010	
E1	0.250	0.250	0.250	0.250	0.250	±0.005	2
e	0.100	0.100	0.100	0.100	0.100	Basic	
eA	0.300	0.300	0.300	0.300	0.300	Basic	
eB	0.345	0.345	0.345	0.345	0.345	±0.025	
L	0.125	0.125	0.125	0.125	0.125	±0.010	
N	8	14	16	18	20	Reference	

Rev. C 2/07

#### NOTES:

1. Plastic or metal protrusions of 0.010" maximum per side are not included.
2. Plastic interlead protrusions of 0.010" maximum per side are not included.
3. Dimensions E and eA are measured with the leads constrained perpendicular to the seating plane.
4. Dimension eB is measured with the lead tips unconstrained.
5. 8 and 16 lead packages have half end-leads as shown.

All Intersil U.S. products are manufactured, assembled and tested utilizing ISO9000 quality systems.  
Intersil Corporation's quality certifications can be viewed at [www.intersil.com/design/quality](http://www.intersil.com/design/quality)

*Intersil products are sold by description only. Intersil Corporation reserves the right to make changes in circuit design, software and/or specifications at any time without notice. Accordingly, the reader is cautioned to verify that data sheets are current before placing orders. Information furnished by Intersil is believed to be accurate and reliable. However, no responsibility is assumed by Intersil or its subsidiaries for its use; nor for any infringements of patents or other rights of third parties which may result from its use. No license is granted by implication or otherwise under any patent or patent rights of Intersil or its subsidiaries.*

For information regarding Intersil Corporation and its products, see [www.intersil.com](http://www.intersil.com)