

Connector for SD Memory Card

SCDA Series

A highly reliable contact structure makes a thickness of only 2.75 mm possible.

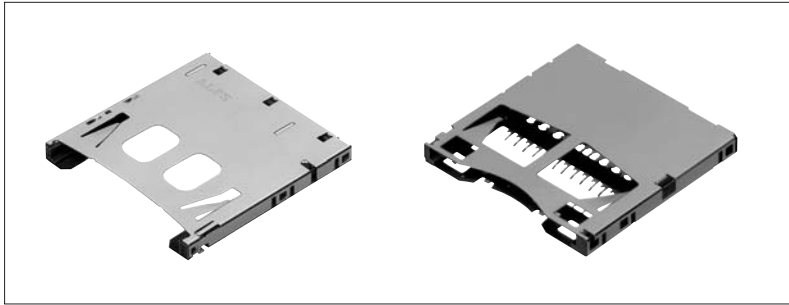

Connector for
SD Memory Card

Connector for
TransFlash™
Card

Connector for
miniSD™ Card

Connector for
RS-MMC™

Connector for
Memory Stick Duo™

Connector for
Memory Stick™

Combine
Type
Connectors

Connector for
Compact Flash™
Card

IC Card
Connectors

PC Card
Connectors

Connector for
CMOS Camera
Module

Features

- To defend from loss when memory card was ejected, half-lock structure is adopted.
- Media detection switch adopts highly reliable contact structure with sliding at ON/OFF. Media detection switch surely detects timing when media are inserted.
- Available for both SD Memory Card and MultiMediaCard™.
- Compact size and low-profile.

Applications

- Mobile phone, personal computers, digital cameras, digital camcorders, personal digital assistants and etc.
- Home audio and visual equipment (TV, set top box and etc.)

Typical Specifications

Items		Specifications
Structure	Applicable media	SD Memory Card / MultiMediaCard™
	Mounting method	Surface mounting type
	Mounting system	Standard / Reverse mount
	Media ejection structure	Push-push type / Header type
Performance	Operating temperature range	-25°C to +60°C
	Voltage proof	500V AC 1minute
	Insulation resistance(Initial)	1,000MΩ min.
	Contact resistance(Initial)	100mΩ max.
	Mating and unmating cycle	10,000 cycles

Products List

Media ejection structure	Mounting system	Features	Compatible with SD I/O	Stand-off (mm)	Packing system	Product No.	Drawing No.
Push-push type	Standard mount	—	○	0	Taping	SCDA1A0900	1
						SCDA1A0901	1
						SCDA1A0801	2
						SCDA1A1401	3
						SCDA1A1501	4
	Reverse mount	—	○	0	Taping	SCDA1A0703	6
						SCDA1A0704	6
	Standard mount Inner tail type	Without frame legs With frame With shutter	○	0	Taping	SCDA2A0300	7
						SCDA2A0201	8
						SCDA3A0102	9
	Standard mount	Slim type Header type	○	0	Tray	SCDA3A0202	10
						SCDA3B0201	11
Manual couple/decouple type	Standard mount	—	—	0	Taping	SCDA4A0100	12
						SCDA3C0102	13

Connector for SD Memory Card

Connector for TransFlash™ Card

Connector for miniSD™ Card

Connector for RS-MMC™

Connector for Memory Stick Duo™

Connector for Memory Stick™

Combine Type Connectors

Connector for Compact Flash™ Card

IC Card Connectors

PC Card Connectors

Connector for CMOS Camera Module

Dimensions Standard mount

Unit : mm

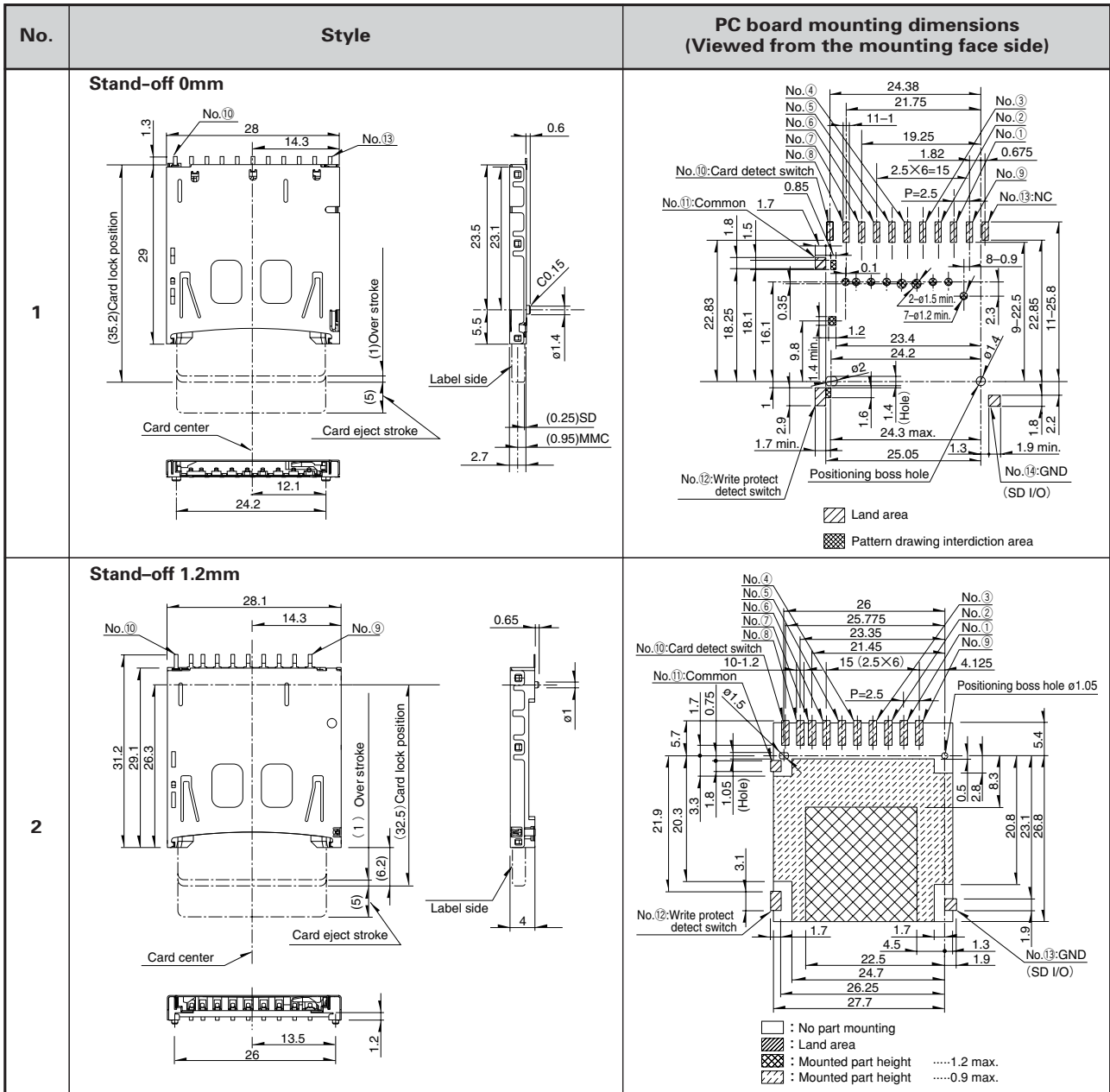

Dimensions
Standard mount

Unit : mm

No.	Style	PC board mounting dimensions (Viewed from the mounting face side)
<p>3</p> <p>Connector for SD Memory Card</p> <p>Connector for TransFlash™ Card</p> <p>Connector for miniSD™ Card</p> <p>Connector for RS-MMC™</p> <p>Connector for Memory Stick Duo™</p> <p>Connector for Memory Stick™</p> <p>Combine Type Connectors</p> <p>Connector for Compact Flash™ Card</p> <p>IC Card Connectors</p> <p>PC Card Connectors</p> <p>Connector for CMOS Camera Module</p>	<p>Stand-off 1.5mm</p>	<p> : No part mounting : Land area : Mounted part height1.5 max. : Mounted part height1.2 max. </p>
	<p>4</p> <p>Stand-off 1.8mm</p>	<p> : No part mounting : Land area : Mounted part height1.8 max. : Mounted part height1.5 max. </p>

Dimensions
Standard mount

Unit : mm

No.	Style	PC board mounting dimensions (Viewed from the mounting face side)
5	<p>Stand-off 2.3mm</p>	<p> : No part mounting : Land area : Mounted part height2.3 max. : Mounted part height1.8 max. </p>
6	<p>Stand-off -0.8mm</p>	<p> : No part mounting : Land area </p>

Connector for SD Memory Card

Connector for TransFlash™ Card

Connector for miniSD™ Card

Connector for RS-MMC™

Connector for Memory Stick Duo™

Connector for Memory Stick™

Combine Type Connectors

Connector for Compact Flash™ Card

IC Card Connectors

PC Card Connectors

Connector for CMOS Camera Module

Dimensions
Reverse mount

Unit : mm

No.	Style	PC board mounting dimensions (Viewed from the mounting face side)
<p>7</p> <p>Connector for SD Memory Card</p> <p>Connector for TransFlash™ Card</p> <p>Connector for miniSD™ Card</p> <p>Connector for RS-MMC™</p> <p>Connector for Memory Stick Duo™</p> <p>Connector for Memory Stick™</p> <p>Combine Type Connectors</p> <p>Connector for Compact Flash™ Card</p> <p>IC Card Connectors</p> <p>PC Card Connectors</p>	<p>Stand-off 0mm</p>	
<p>8</p> <p>Connector for CMOS Camera Module</p>	<p>Stand-off 1.8mm</p>	

Dimensions
Standard mount (Inner tail)

Unit : mm

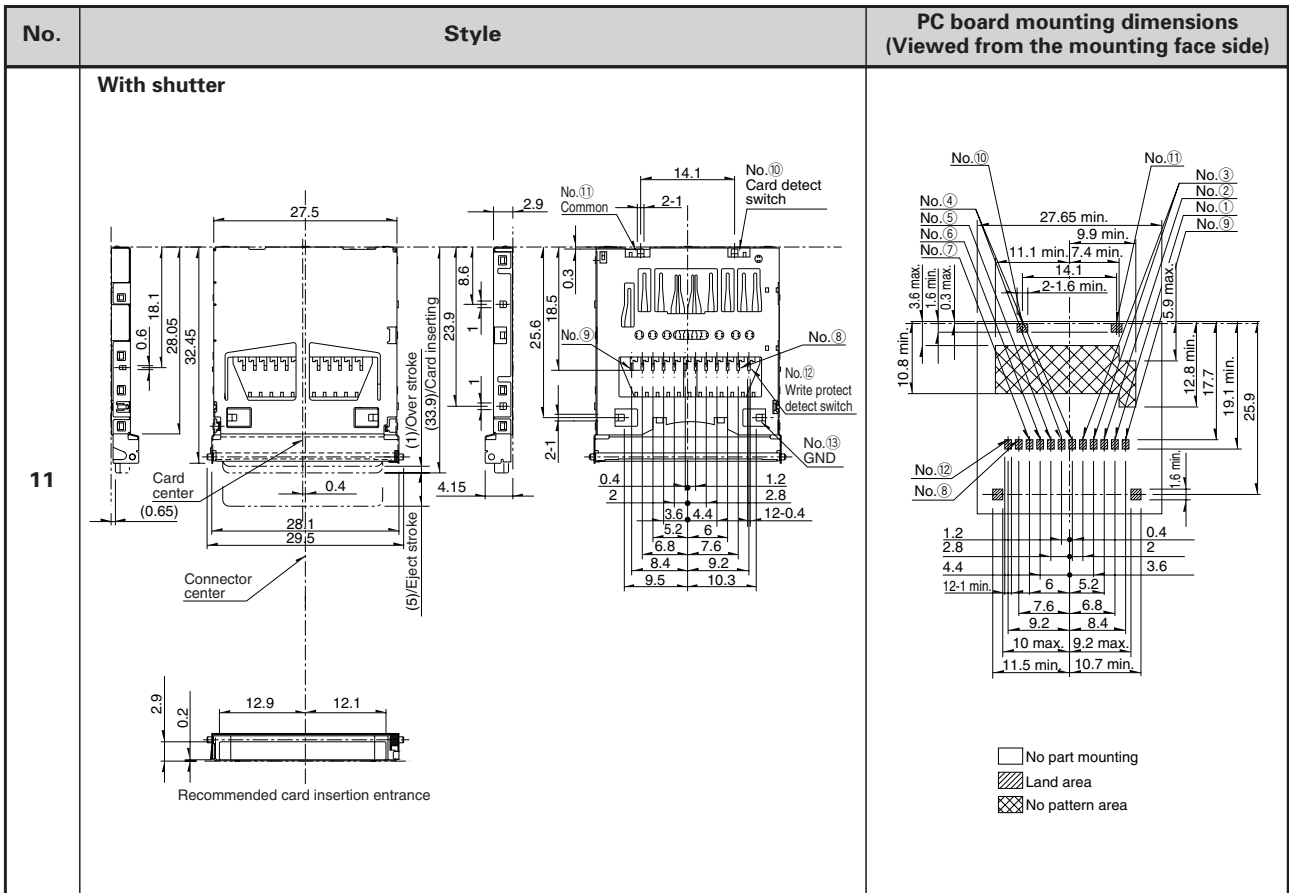

Dimensions
Slim type

Unit : mm

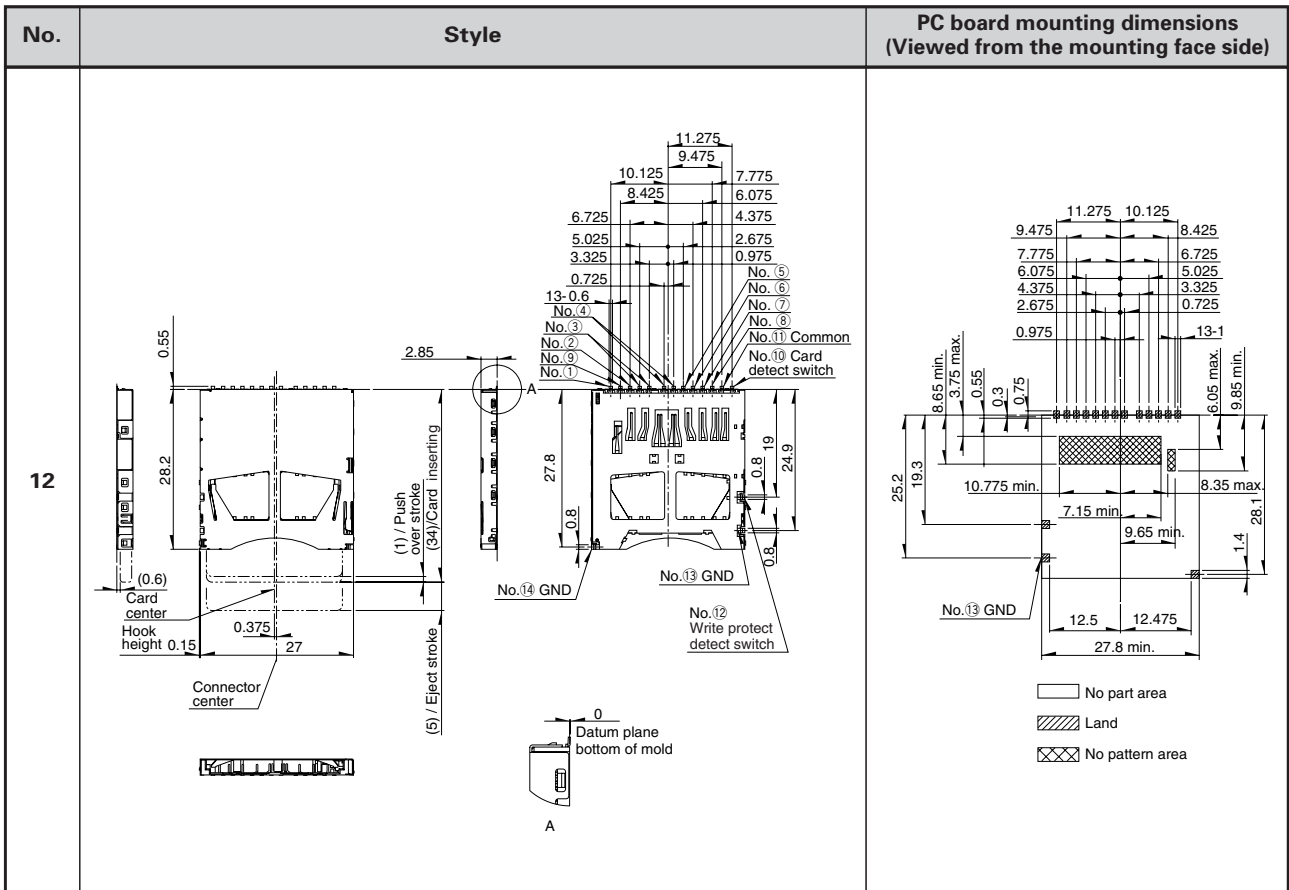

Dimensions
Header type

Unit : mm

No.	Style
13	
<p>PC board mounting dimensions (Viewed from the mounting face side)</p>	

- Connector for SD Memory Card
- Connector for TransFlash™ Card
- Connector for miniSD™ Card
- Connector for RS-MMC™
- Connector for Memory Stick Duo™
- Connector for Memory Stick™
- Combine Type Connectors
- Connector for Compact Flash™ Card
- IC Card Connectors
- PC Card Connectors
- Connector for CMOS Camera Module

Soldering Conditions

Example of Reflow Soldering Condition (Reference)

1. Heating method: Double heating method with infrared heater.
2. Temperature measurement: Thermocouple 0.1 to 0.2 ϕ CA (K) or CC (T) at soldering portion.
3. Temperature profile

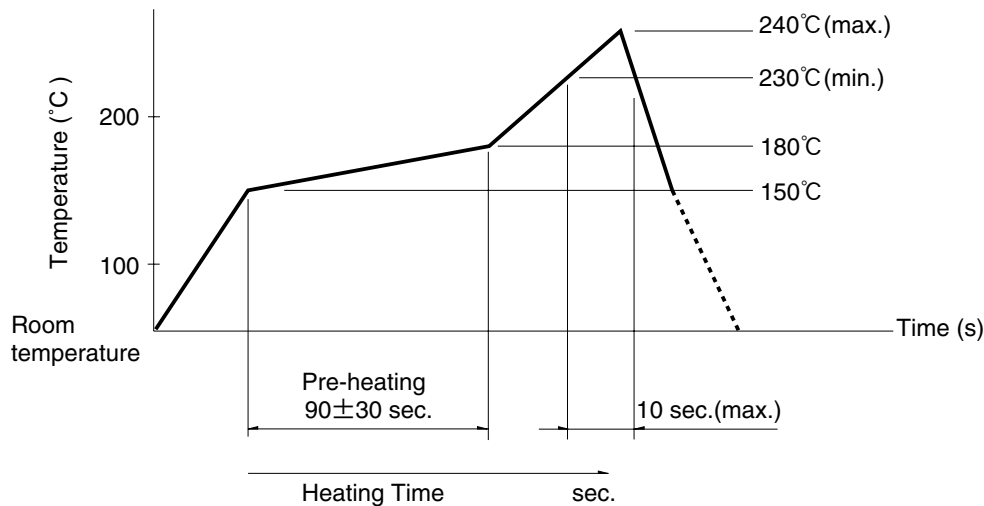

Cautions

1. When soldering terminals, there is a danger that load placed on the terminals may cause rattle, deformation or electrical degradation to occur depending on the conditions. Caution is therefore required.
2. When soldering, do not use water soluble flux because this may corrode the product.
3. Regarding the setting of reflow conditions, please confirm them with the actual mass production conditions.
4. As PC board warping may alter characteristics, please take this into consideration when designing pattern and layout.
5. This product has been designed and manufactured for applications to ordinary electronic equipment and devices such as the AV equipment, electric home applications, office machines and communications equipment, consequently, when employing these products for applications requiring a high degree of safety and reliability such as the medical equipment, aviation and aircraft equipment, space equipment and burglar alarm equipment, the using manufacturers will please thoroughly study the proprieties of these products for the planned applications.

Connector for
SD Memory Card

Connector for
TransFlash™
Card

Connector for
miniSD™ Card

Connector for
RS-MMC™

Connector for
Memory Stick Duo™

Connector for
Memory Stick™

Combine
Type
Connectors

Connector for
Compact Flash™
Card

IC Card
Connectors

PC Card
Connectors

Connector for
CMOS Camera
Module